

STAGE 2

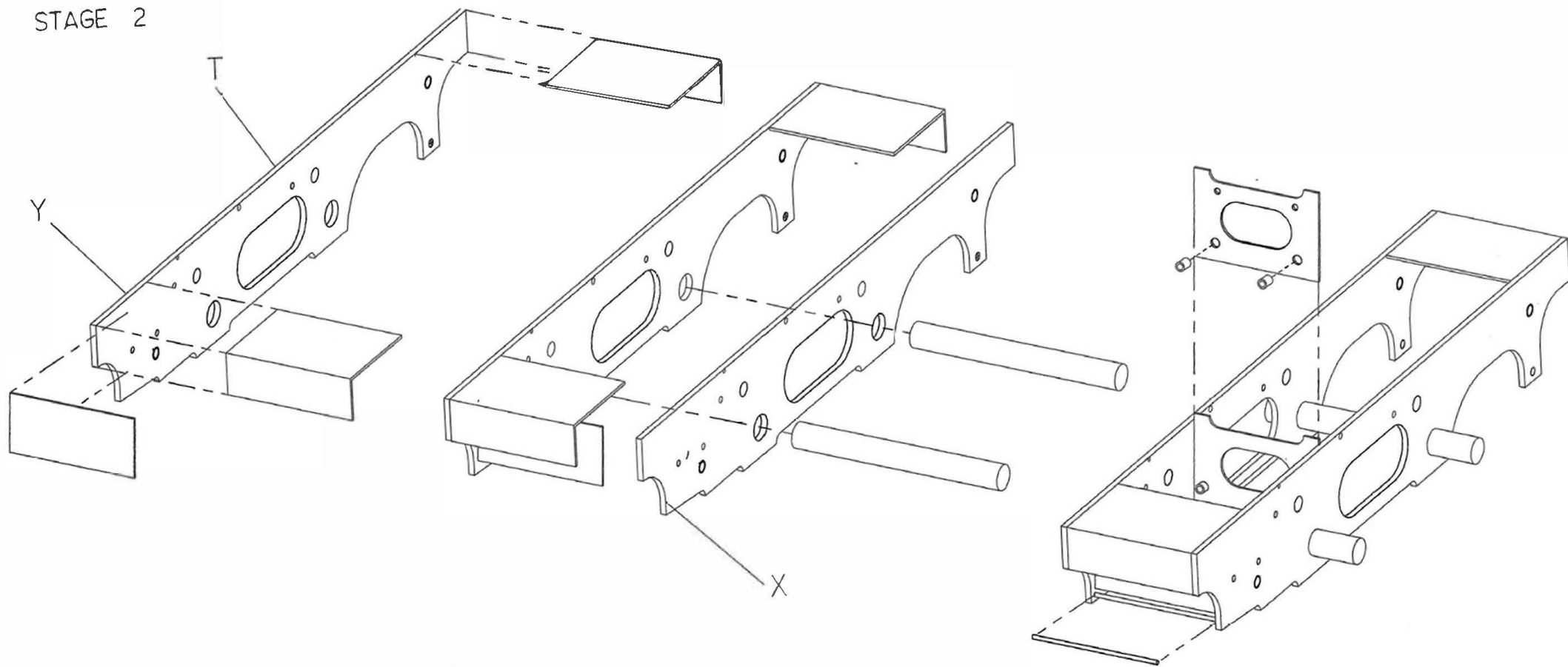

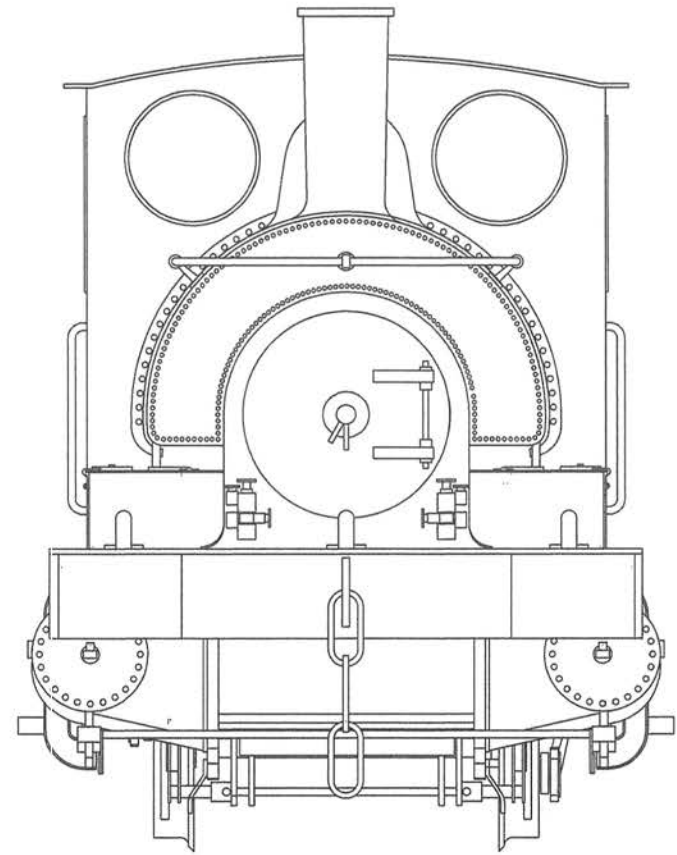

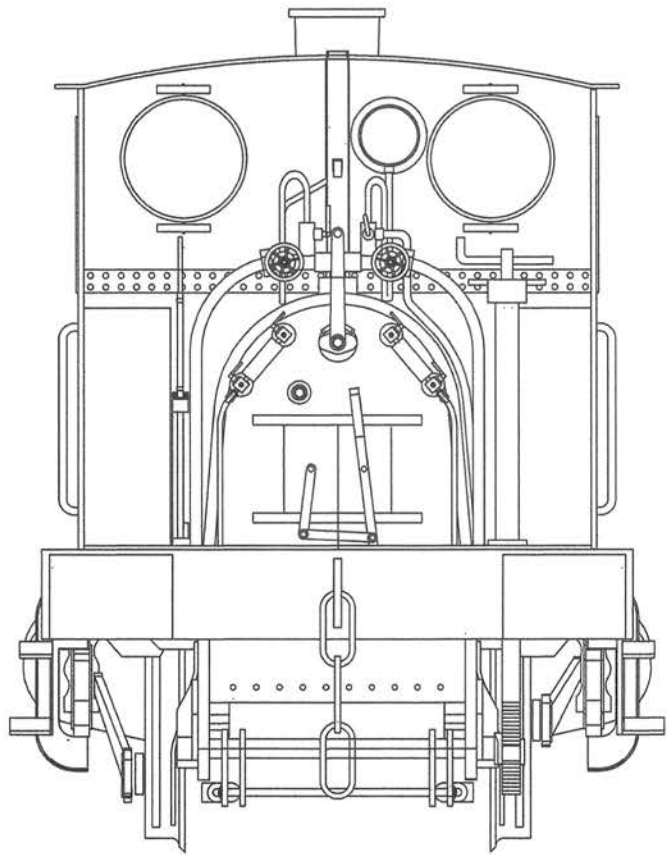

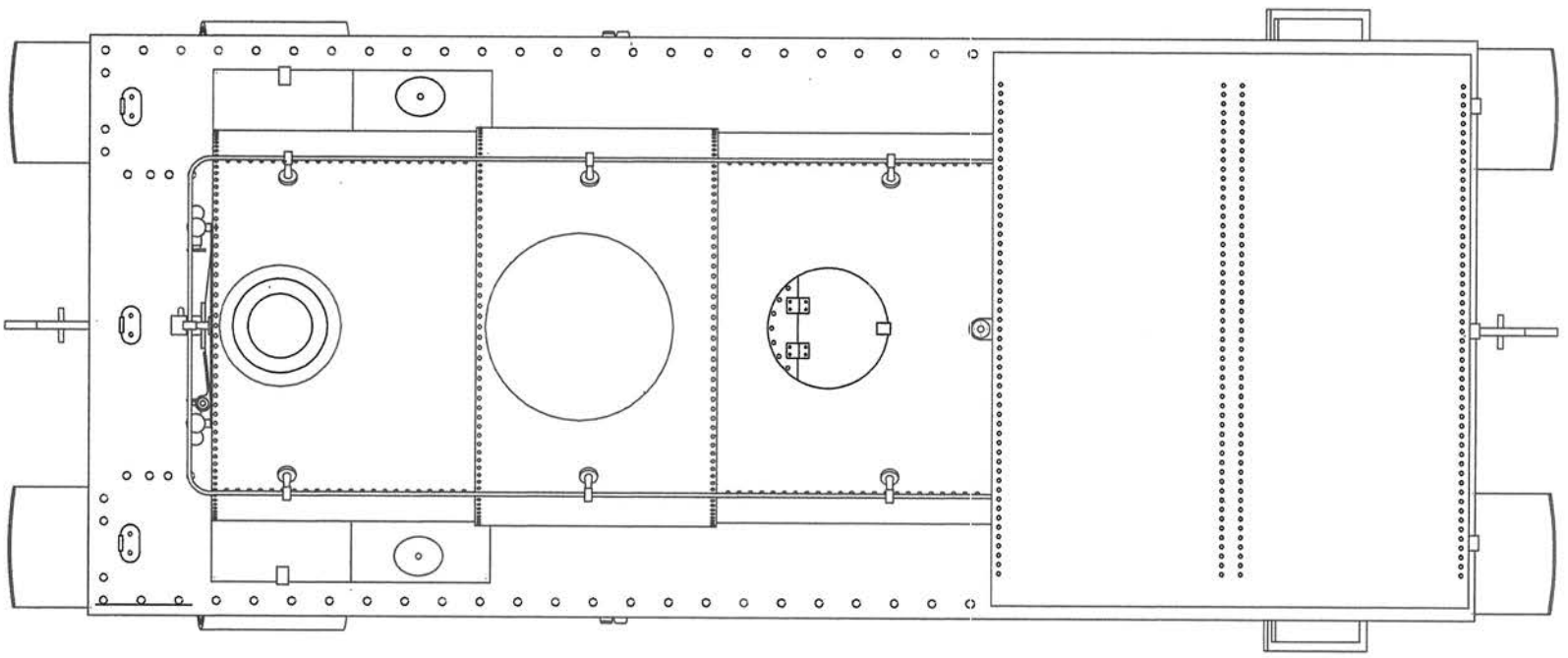
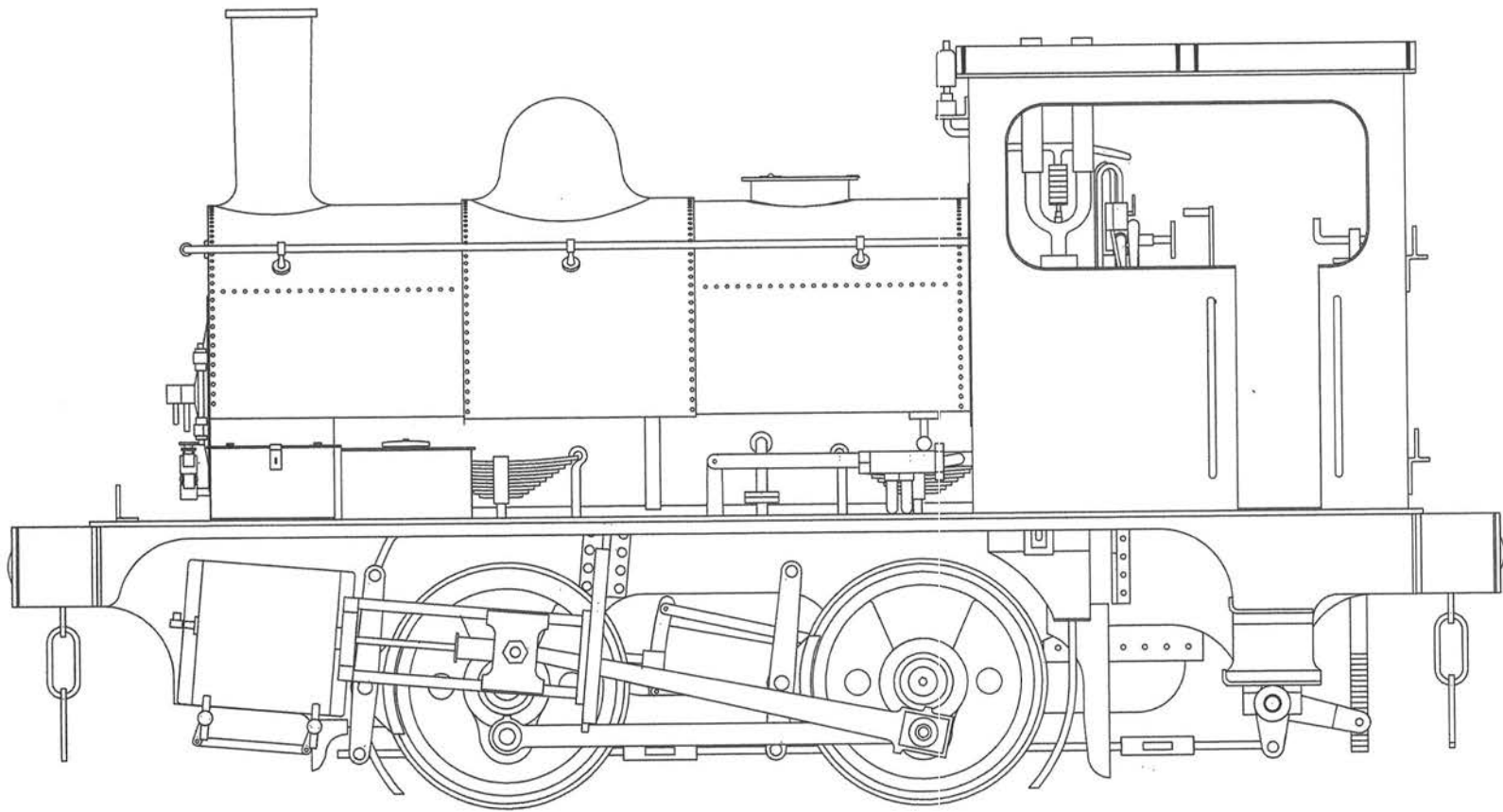

FRAME STAGE 1

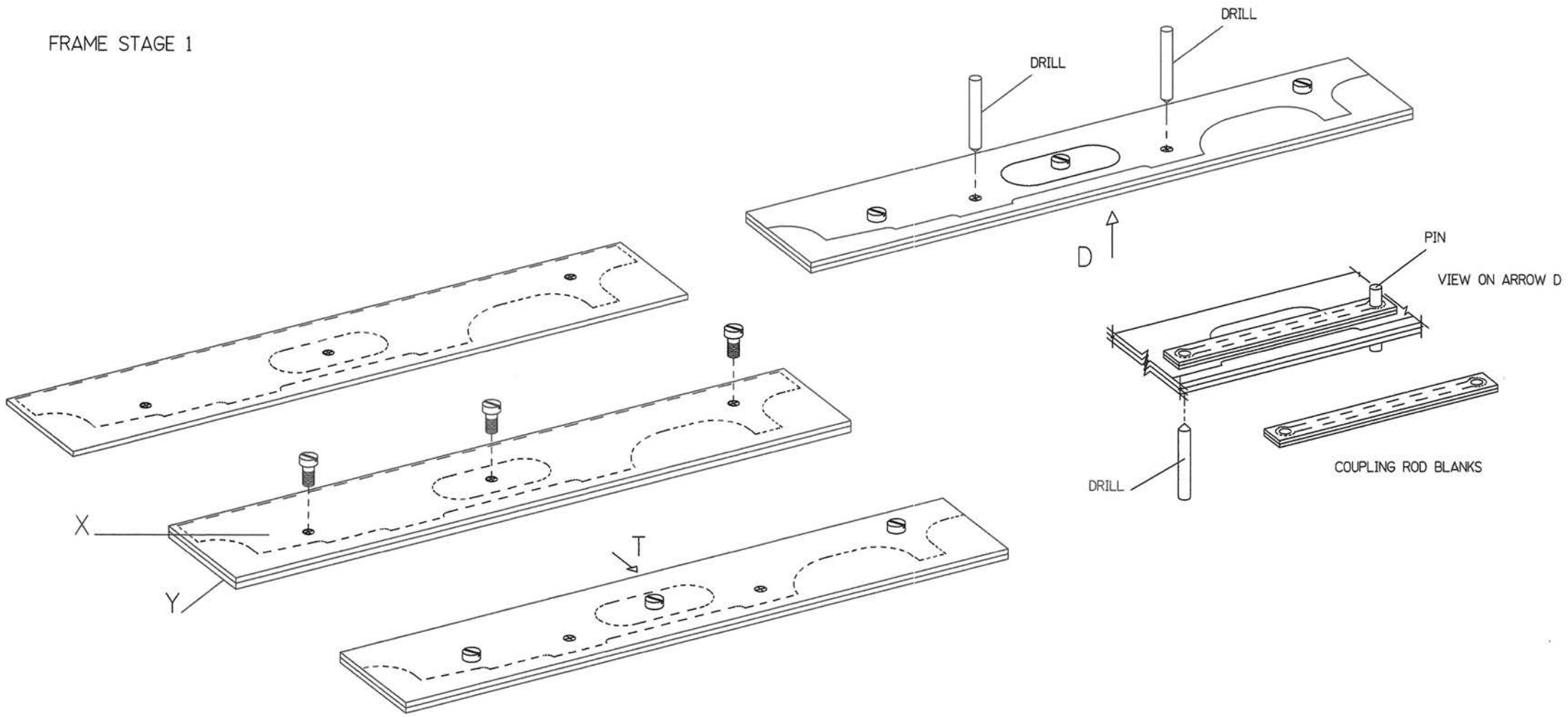

STAGE 1 A

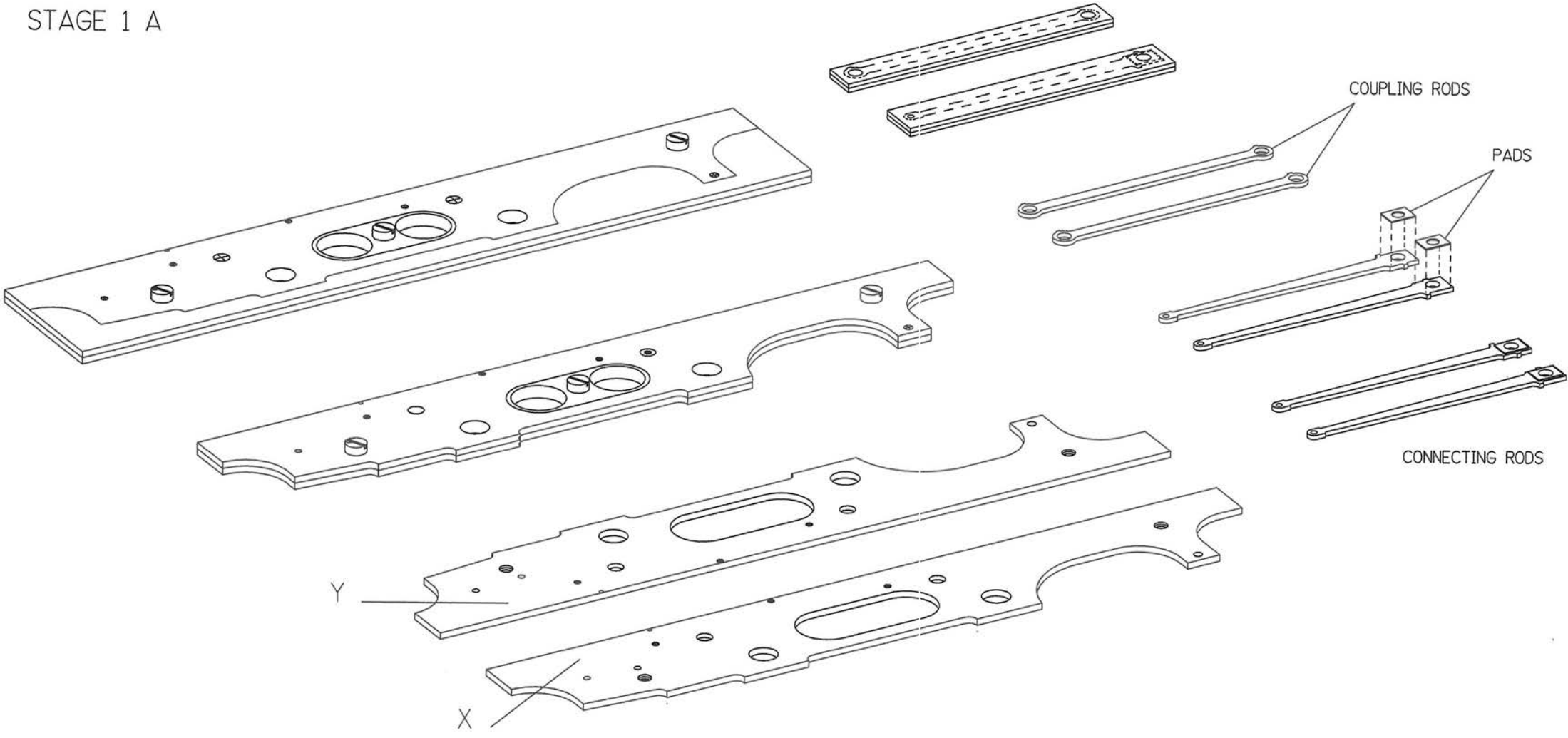

STAGE 3

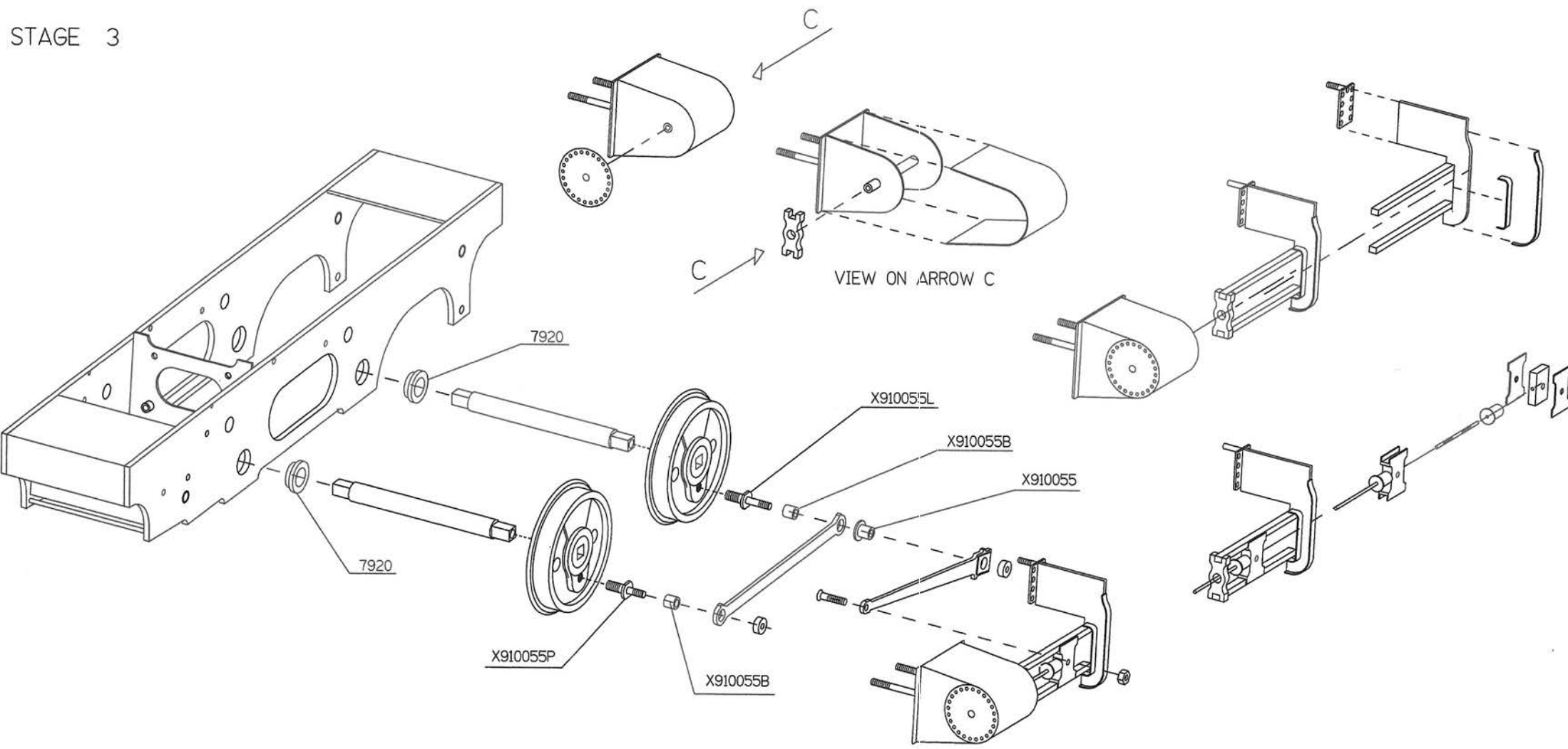

STAGE 4

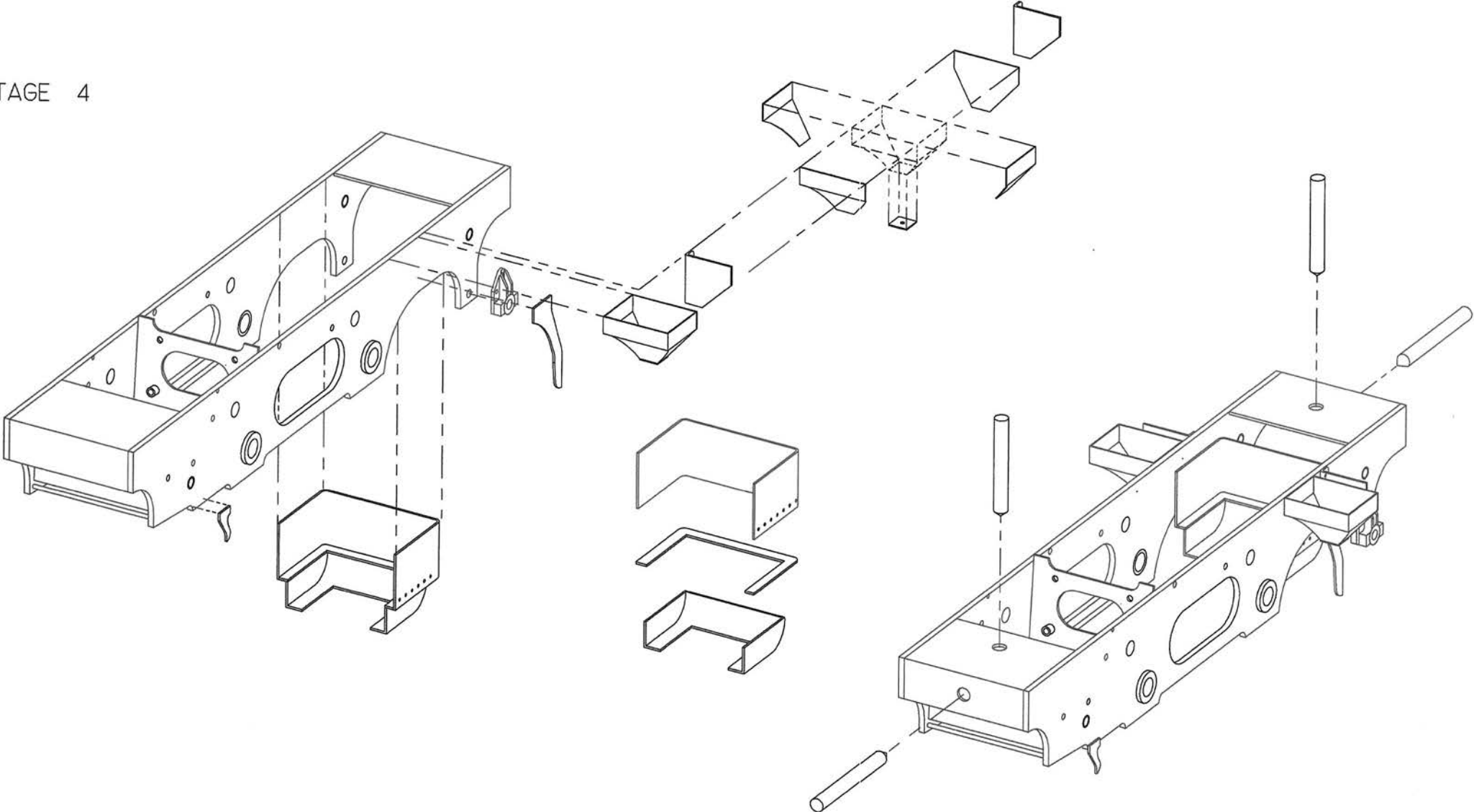

STAGE 5

PLASTIKARD

MASHIMA 1833

PLUNGER PICKUP
REF 7157

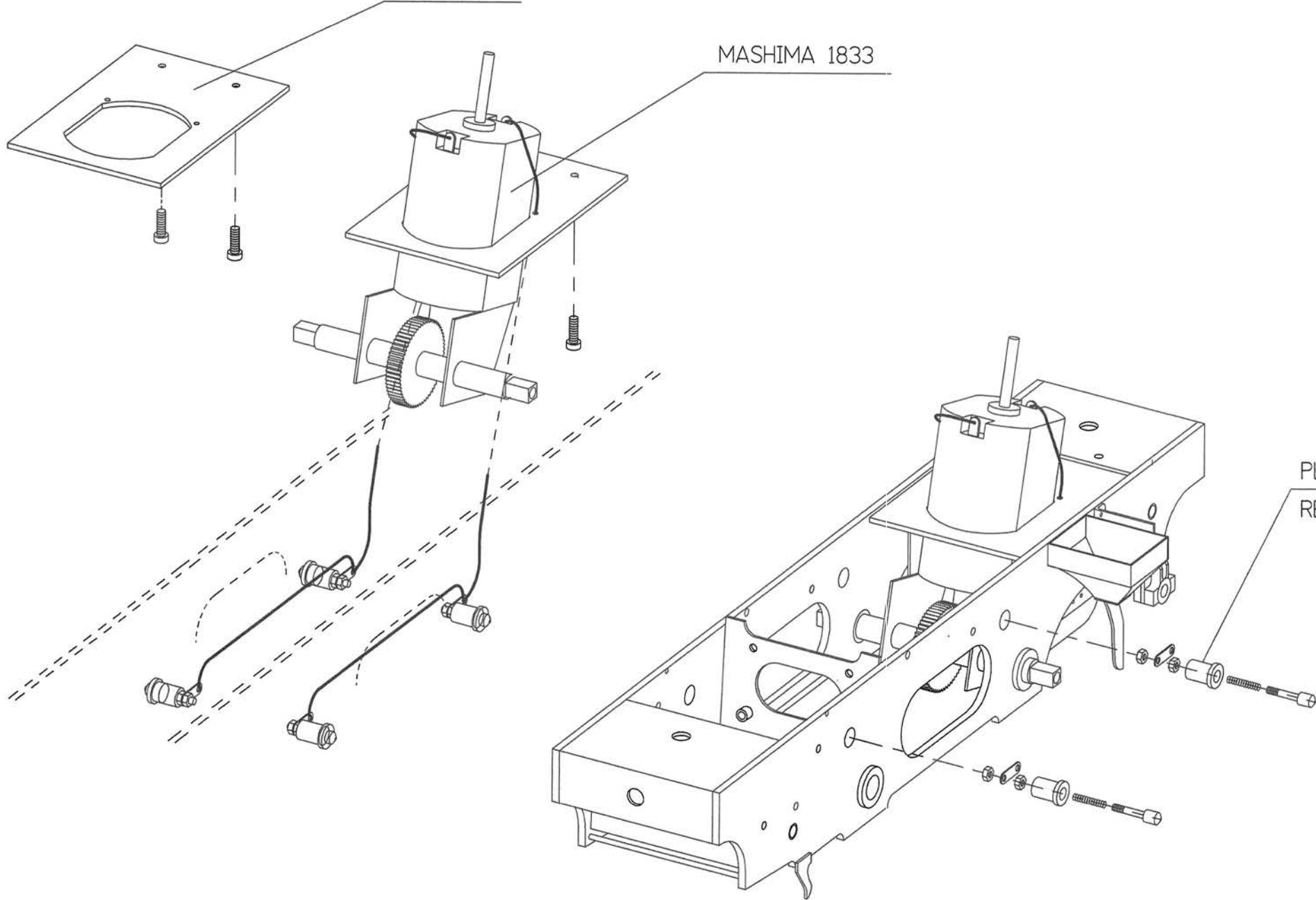

STAGE 6

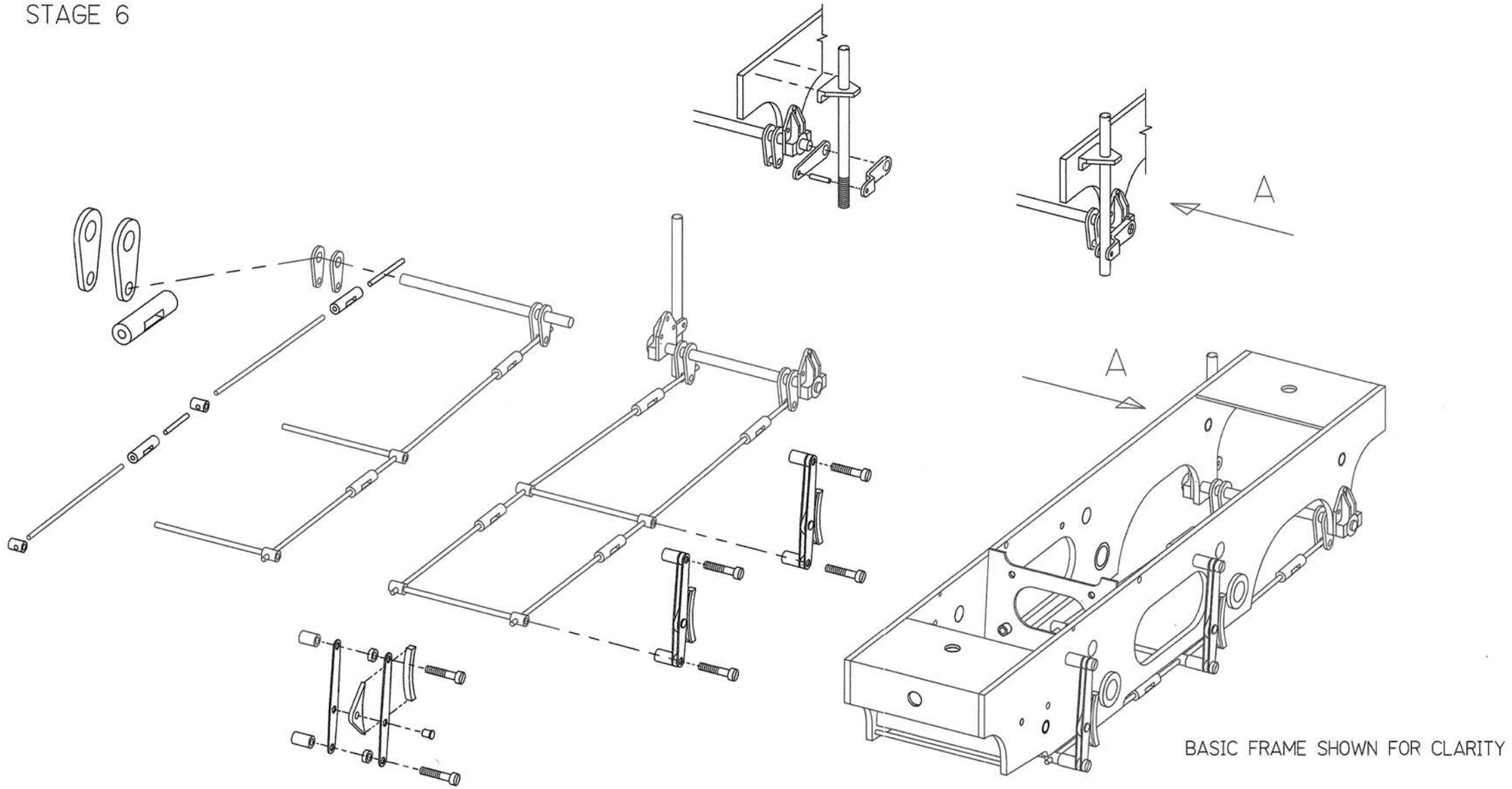

STAGE 7

ELECTRICS OMITTED FOR CLARITY

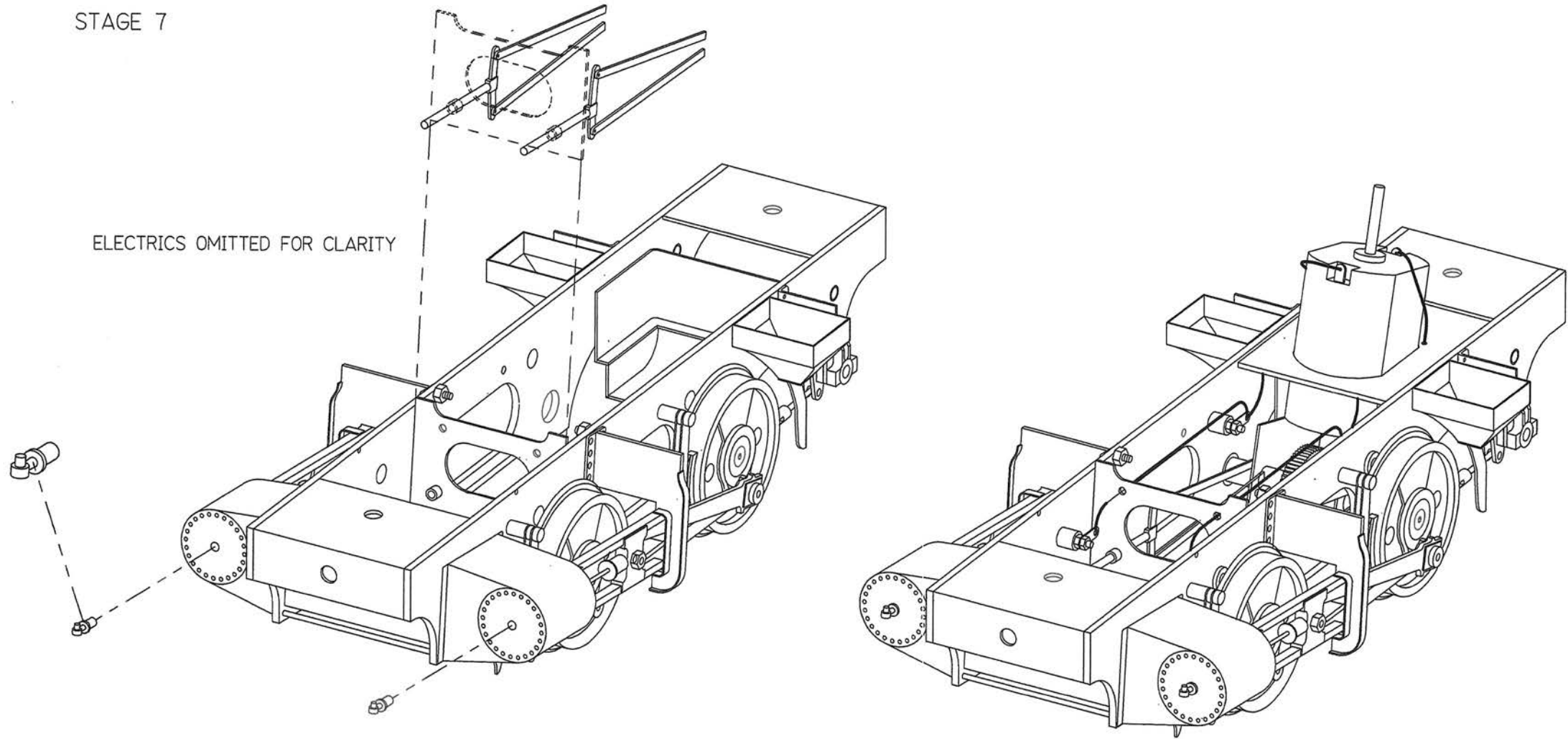

STAGE 8

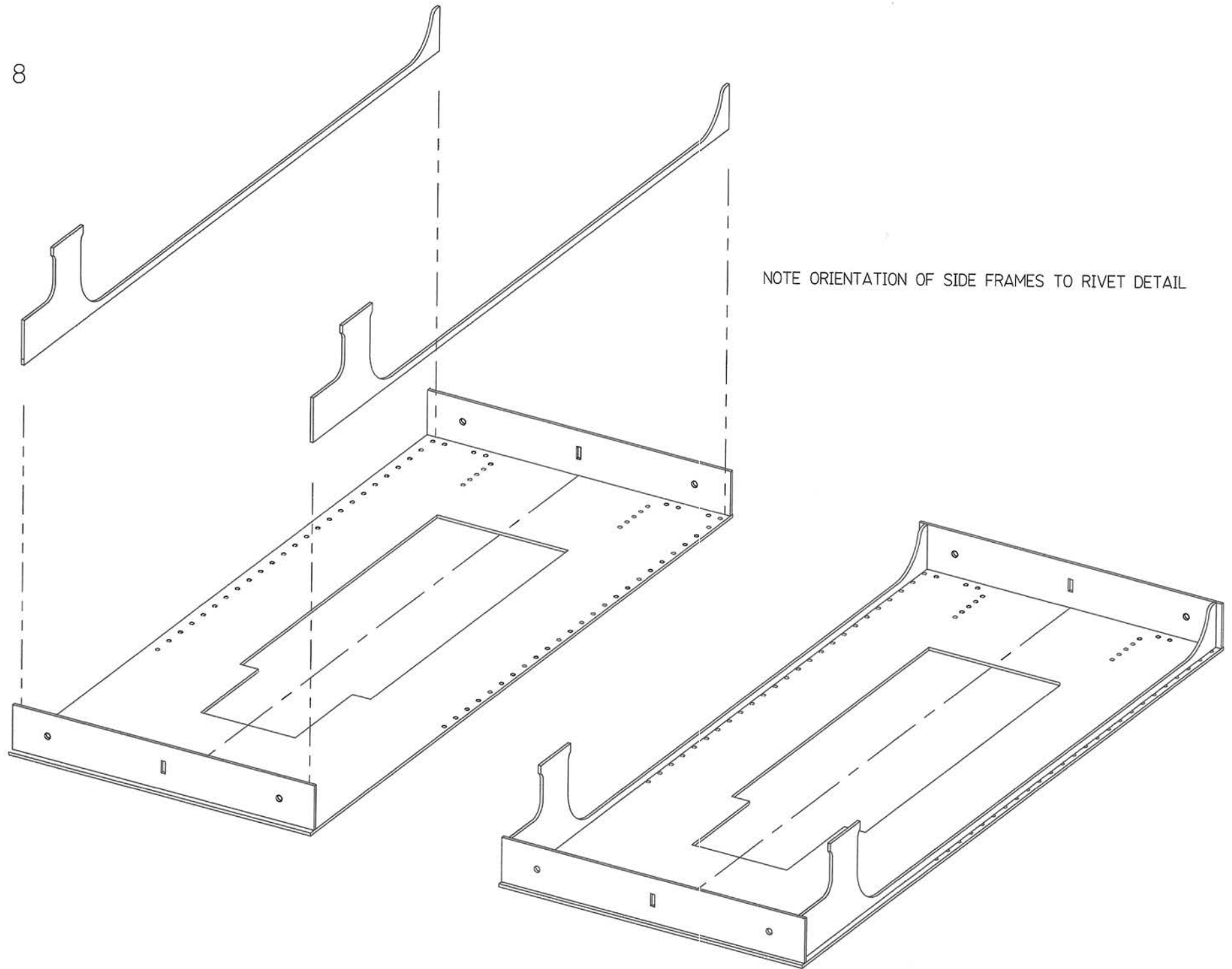

NOTE ORIENTATION OF SIDE FRAMES TO RIVET DETAIL

STAGE 10

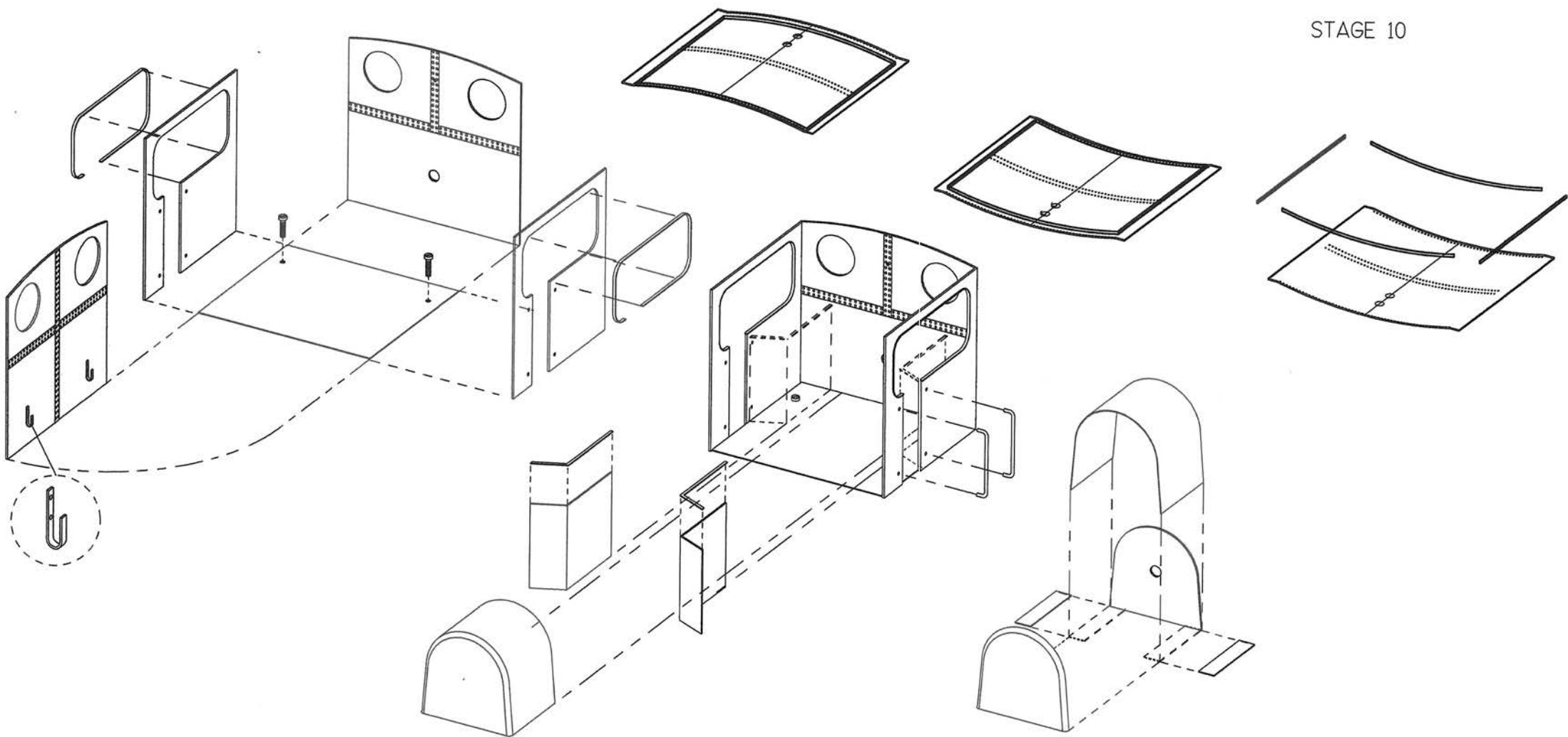

STAGE 11

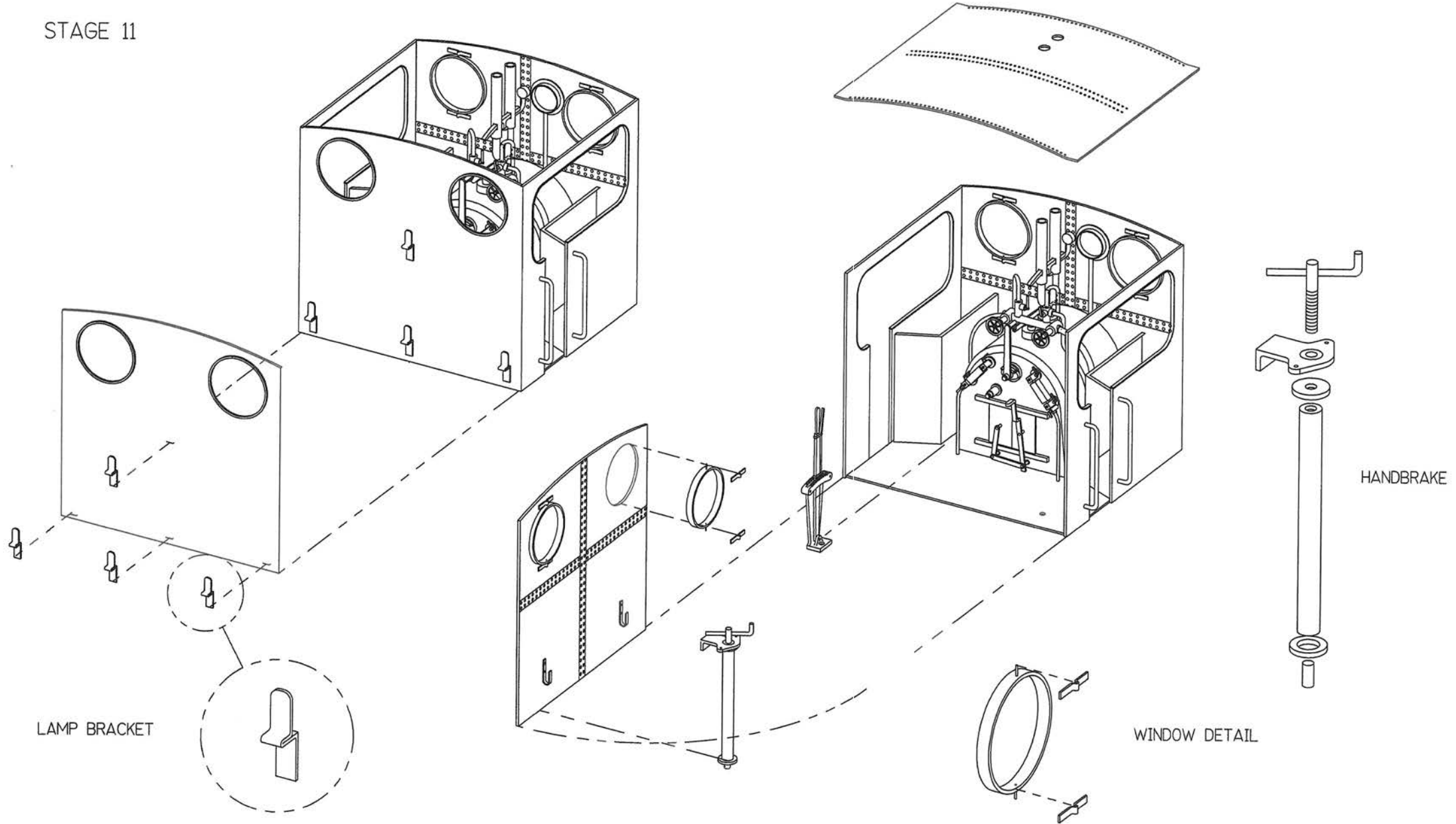

STAGE 12

FIREBOX DETAILS

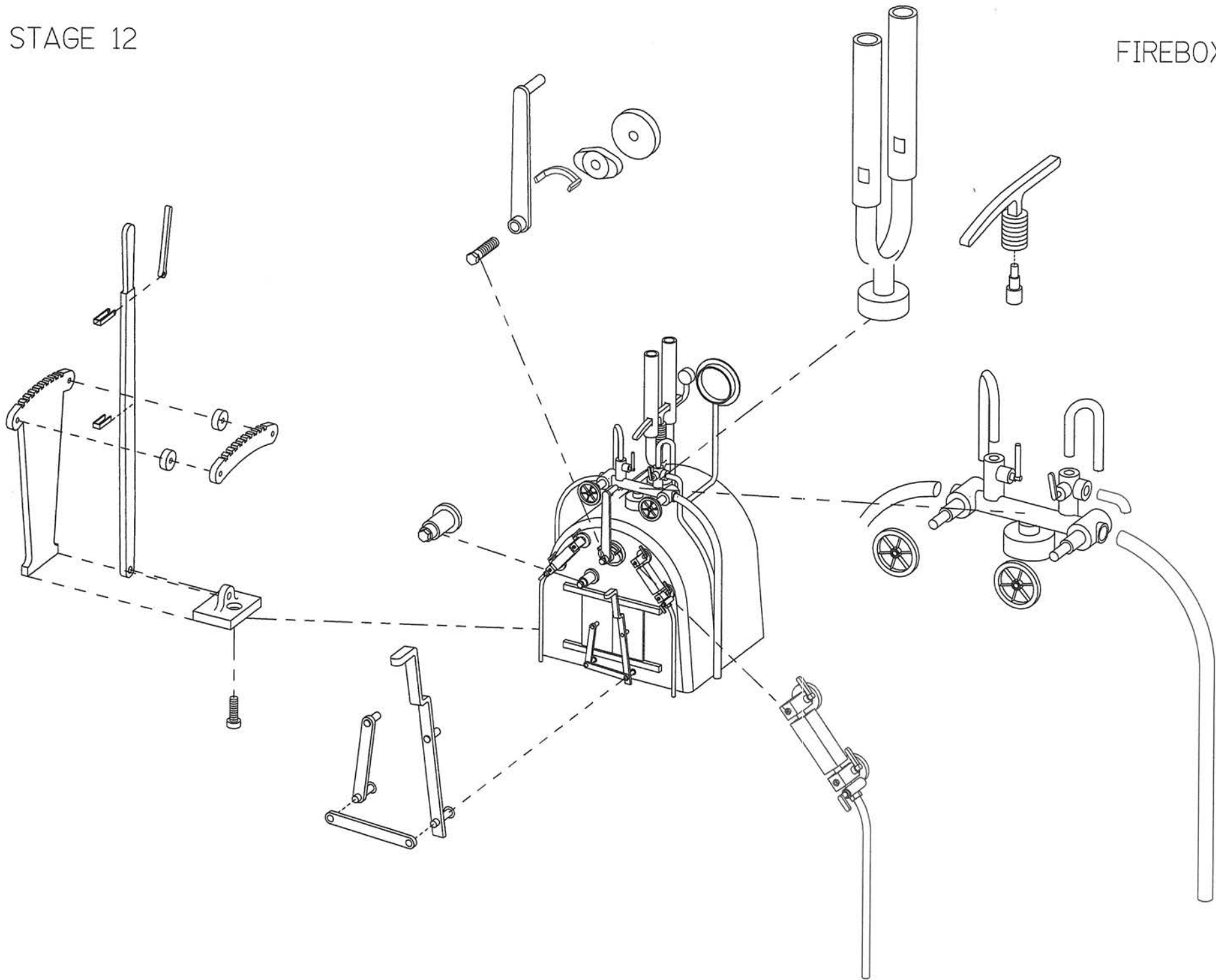

STAGE 13

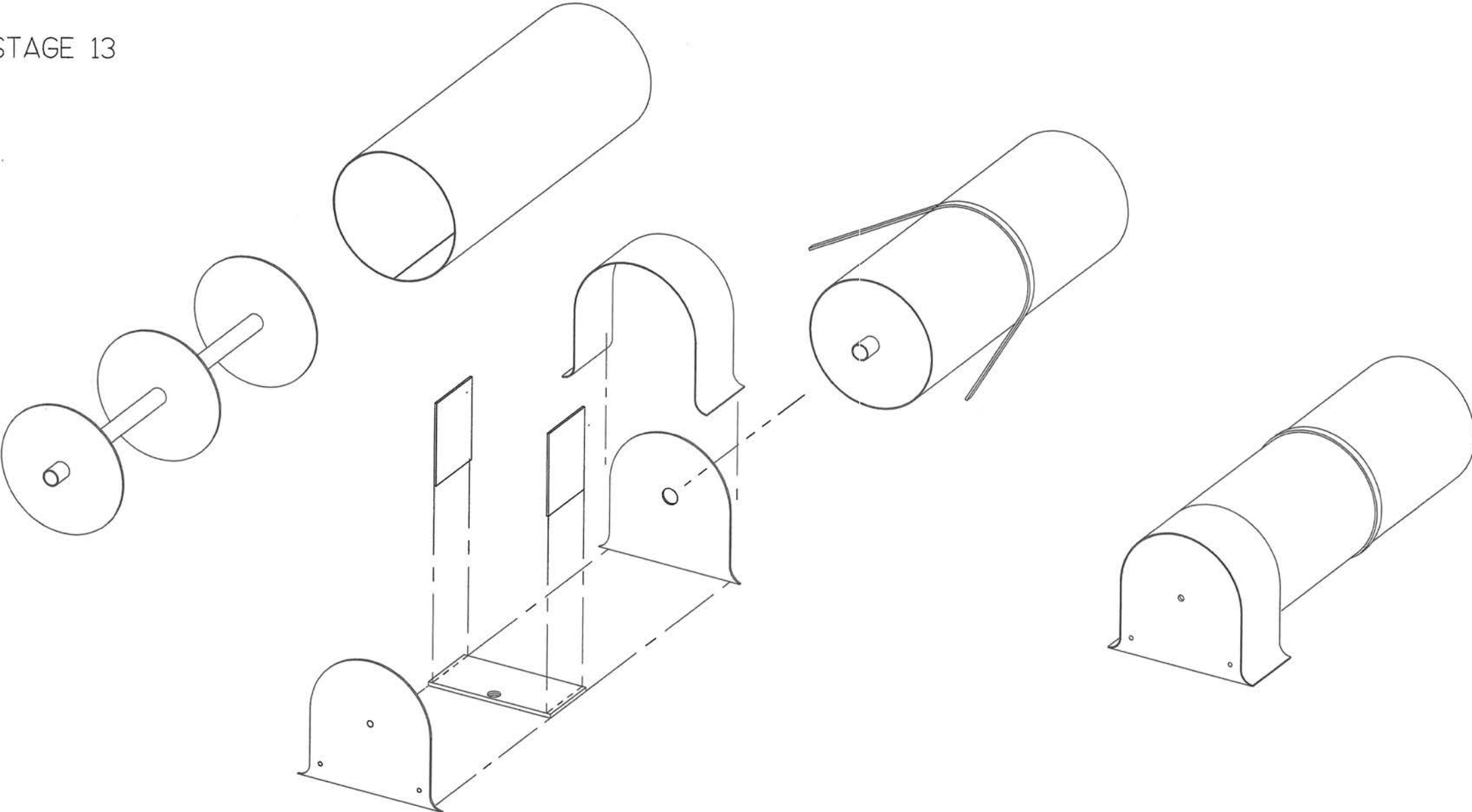

STAGE 14

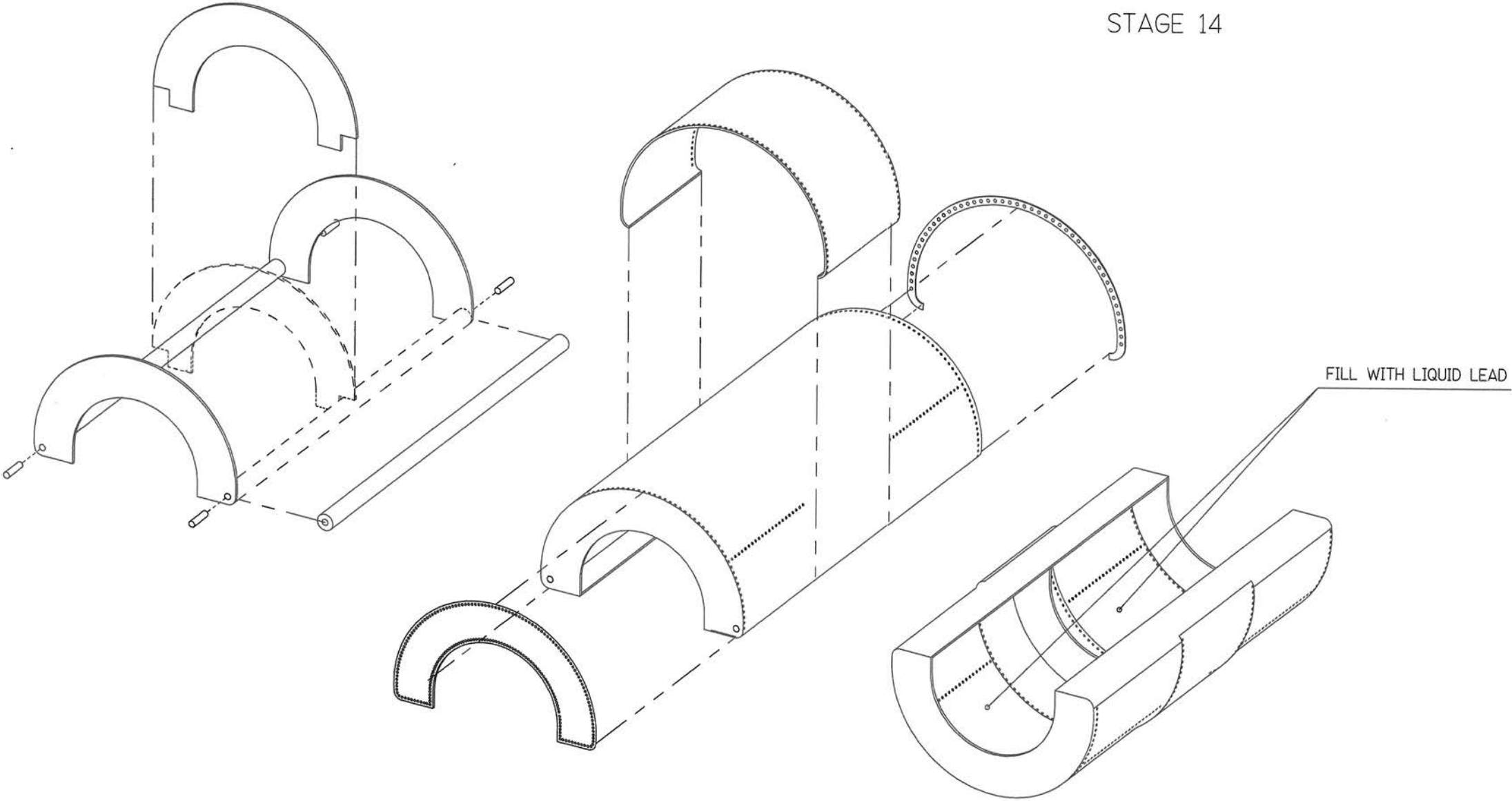

STAGE 15

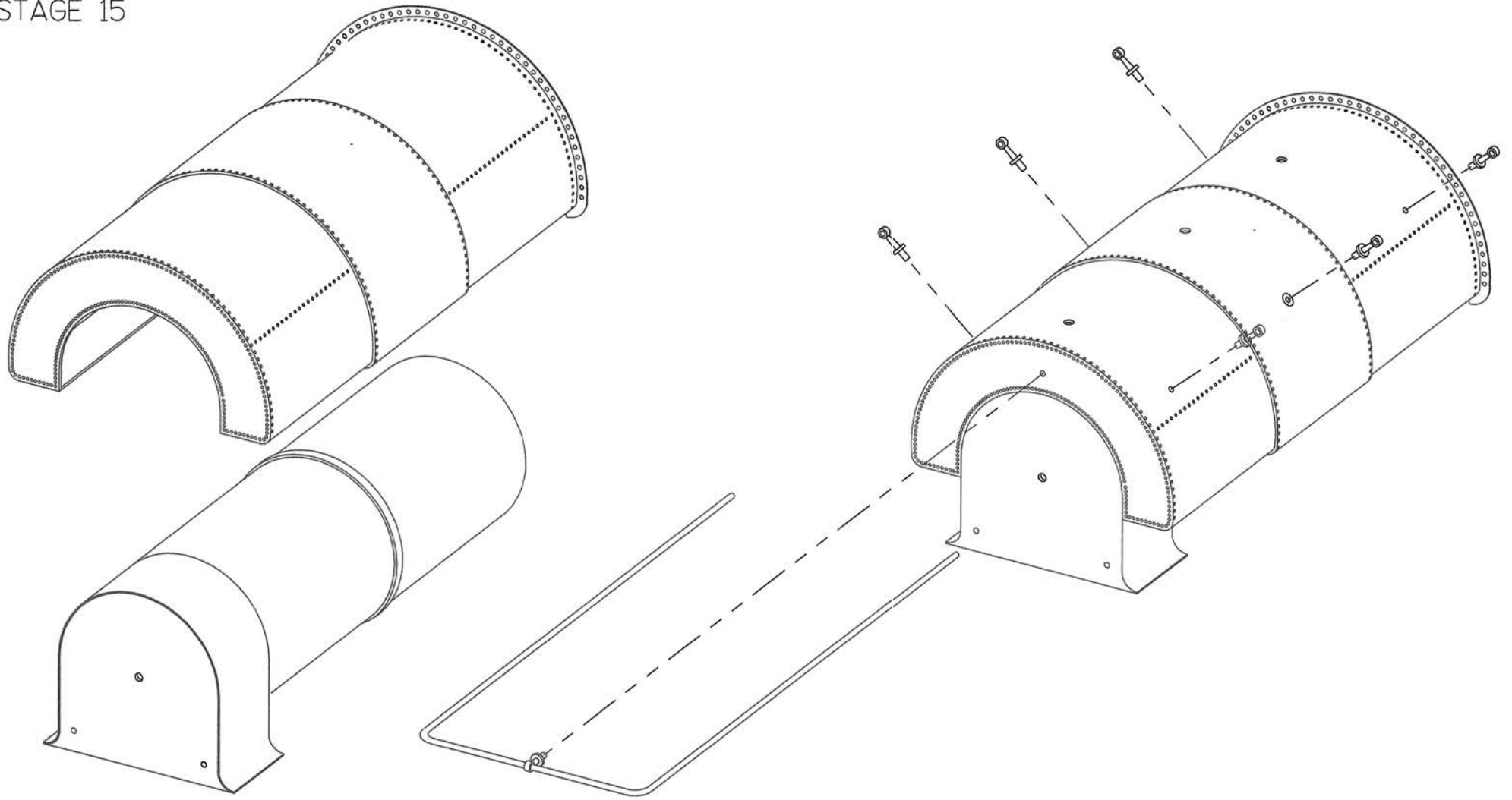

STAGE 16

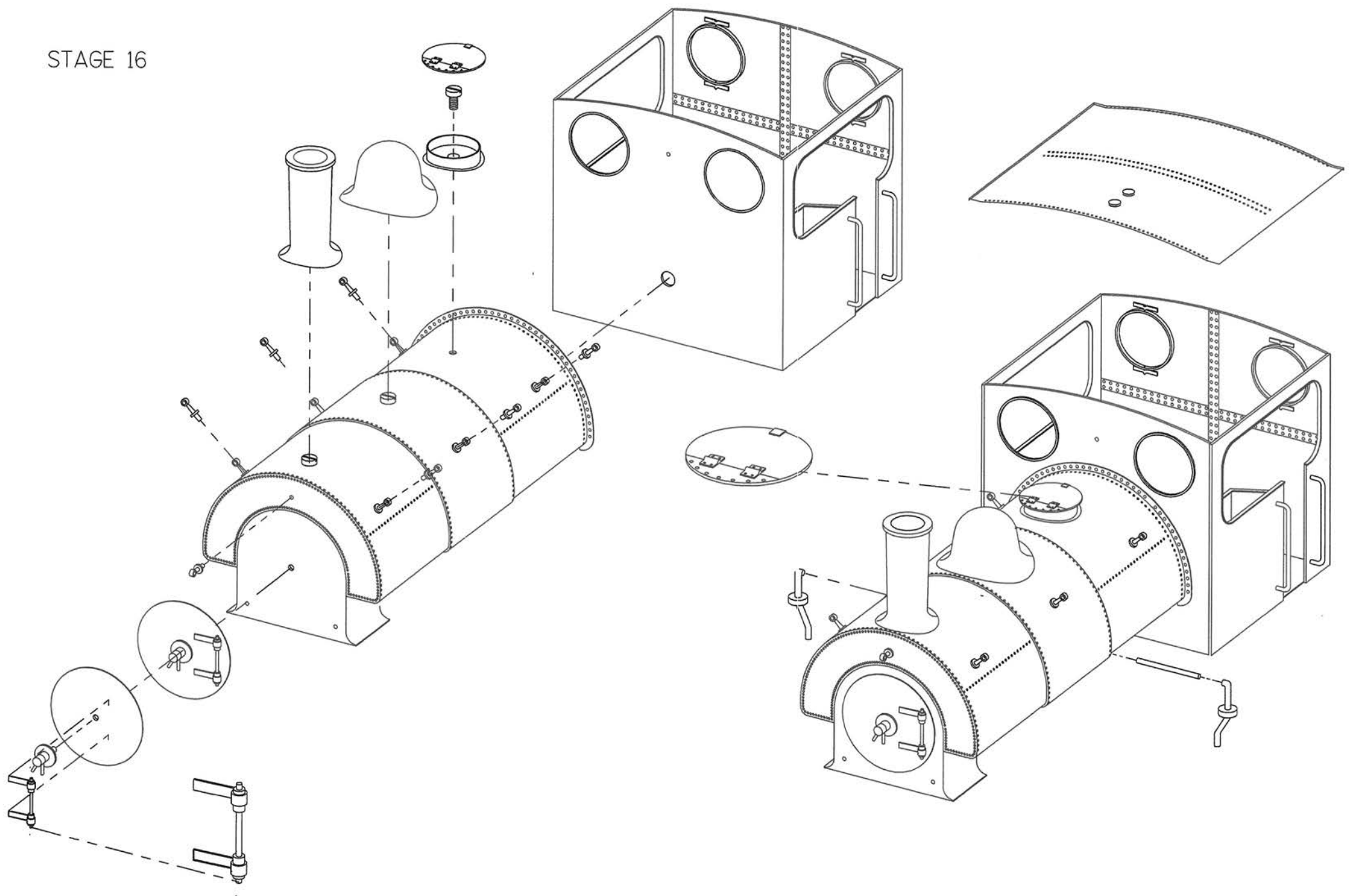

STAGE 17

FINAL ASSEMBLY

